

CS-21-280

BOCC CONTRACT APPROVAL FORM

(Request for Contract Preparation)

CONTRACT TRACKING NO.
CM3207

GENERAL INFORMATION

Requesting Department Facilities Maintenance

Contact Person: Evelyn Burton

Telephone: (904) 530-6125 Fax: (904) 879-3751 Email: eburton@nassaucountyfl.com

CONTRACTOR INFORMATION

Name: MCS Mechanical Contractor Inc.

Address: 3081 Barbara Lane Hilliard FL 32046
City State Zip

Contractor's Administrator Name: Michael Shott Title: President

Telephone: (904) 545-0929 Fax: () Email: mcsmechanical@windstream.net

IDENTIFY WHO WILL SIGN CONTRACT ON BEHALF OF CONTRACTOR (NAME AND EMAIL ADDRESS)

Authorized Signatory Name: Michael Shott

Authorized Signatory Email: mcsmechanical@windstream.net

CONTRACT INFORMATION

Contract Name: NCSO Mechanic's Garage Outside Air System / Foam Insulation

Description: Installation of an outside air system and foam insulation at the Sheriff's Office mechanic's garage
GOODS AND/OR SERVICES TO BE PROCURED, PHYSICAL LOCATION, ETC.

Total Amount of Contract: \$198,733.00
APPROXIMATE IF NECESSARY

Source of Funds/Account: 01076521-562002 Termination/Cancellation: 30 days
C0100

Authorized Signatory: Jeff Gray

IDENTIFY WHO WILL SIGN CONTRACT ON BEHALF OF BOCC

Contract Dates: From: Execution to: 180 days

Status: New Renew Amend# WA/Task Order

How Procured: Sole Source Single Source ITB RFP RFQ Coop. Other

If Processing an Amendment:

Contract #: _____ Increased Amount to Existing Contract: _____

New Contract Dates: _____ to _____ Total or Amended Amount: _____

Continued on next page

CHECKLIST		
<i>Review/Complete before sending contract for final signature</i>		
Requirement	Description	Complete By
Contract, Exhibits and Appendices	1) The contract and all documents incorporated by reference in the contract, including exhibits and appendices are attached (including E-Verify, Pricing, Scope, etc.) and properly identified; and 2) All such documents have been read and agreed to in their entirety by originating department and staff members who have obligations under this contract.	Dept
Name, Address, Contact Person	The full name, address, legal status (i.e., corporation, partnership, etc.) and contact person of other party are included.	Dept
Understanding	Written contract matches the verbal understanding of all parties. All terms and conditions conform to the final negotiations/agreement of the parties.	Dept
Competition/Conflicts and Existing Contracts/Compliance	This contract does not conflict with any other contracts, promises or obligations of the BOCC. The requesting department verifies the BOCC can comply with all terms and conditions.	Dept Cnty Atty
Other Necessary Agreements	All other necessary agreements or waivers referred to in contract have been obtained and are attached and properly identified for reference.	Cnty Atty
Indemnification	BOCC may not indemnify, hold harmless, be liable to, or reimburse any other party to the contract for claims, lawsuits, damages, attorney fees, or losses incurred by that party in connection with the contract.	Cnty Atty
Term of Contract	Start and end dates of contract are included. Any renewals are included.	Cnty Atty
Warranties/Guarantees	Warranties or guarantees give satisfactory protection.	Cnty Atty/Risk
Insurance	Risk manager has or will approve insurance clauses. Levels confirmed in requirements	Dept
Governing Law	The contract is governed under the laws of the State of Florida. The contract may be silent on this issue but in no event will another state's law govern the agreement.	Cnty Atty
Confidentiality Agreements	All nondisclosure clauses include exceptions regarding disclosure as required by law. If not applicable, indicate "n/a."	Cnty Atty
Printed/Typed Names	Names of all persons signing contracts are printed or typed below signatures.	Router

APPROVALS PURSUANT TO NASSAU COUNTY PURCHASING POLICY

1. Doug Podiak 7/11/2022
Department Head/Contract Manager Date
2. Ramon Alvarez 7/11/2022
Procurement Date
- DF 7/12/2022 3. Chris Lacambra 7/12/2022 7/11/2022
Office of Mgmt & Budget Date
4. Denise C. May 7/12/2022
County Attorney Date

COUNTY MANAGER – FINAL SIGNATURE APPROVAL

5. Taso E. Popoy AICP 7/12/2022
County Manager Date

RETURN ORIGINAL(S) TO CONTRACTS MANAGEMENT FOR DISTRIBUTION AS FOLLOWS:

Original: Clerk's Services; Contractor (original or certified copy)
Copies: Department; Procurement; RLS Distribution; Clerk Services BOCC

**CONTRACT FOR OUTSIDE AIR SYSTEM AND FOAM INSULATION
INSTALLATION**

THIS CONTRACT entered into on August 24, 2022, by and between the **BOARD OF COUNTY COMMISSIONERS OF NASSAU COUNTY, FLORIDA, a political subdivision of the State of Florida**, hereinafter referred to as the “County”, and MCS Mechanical Contractor Inc., located at 3081 Barbara Lane, Hilliard, FL 32046, hereinafter referred to as the “Vendor”.

WHEREAS, the County received sealed bids for the installation of an Outside Air System and Foam Insulation for the Nassau County Sheriff’s Office, on April 6, 2022 at 10:00 AM; and

WHEREAS, the Director of Public Works has determined that the Vendor was the lowest, most responsive and responsible bidder. A copy of the Vendor’s Response Price Sheet is attached hereto as Attachment “A” and made a part hereof; and

NOW, THEREFORE, in consideration of the terms and conditions herein set forth, the County and the Vendor agree as follows:

SECTION 1. Description of Services and/or Materials to be Provided

The County does hereby retain the Vendor to provide the services and/or materials further described in the *Technical Specifications/Scope of Work*, a copy of which is attached hereto and incorporated herein as Attachment “B”. This Contract standing alone does not authorize the performance of any work or require the County to place any orders for work. The Vendor shall commence the work in accordance with the issuance of a written Notice to Proceed for services and/or materials issued by the County.

SECTION 2. Receiving/Payment/Invoicing

No payment will be made for services and/or materials without proper County authorization and approval. The County shall pay the Vendor within forty-five (45) calendar days of receipt and acceptance of invoice by the Director of Public Works, pursuant to and in accordance with the promulgations set forth by the State of Florida’s Prompt Payment Act. (Florida Statutes Section 218.70). The Vendor shall also submit a copy of all invoices submitted to Public Works for payment to invoices@nassaucountyfl.com and tconley@nassaucountyfl.com. Payment shall not be made until services and/or materials have been received, inspected and accepted by the County in the quantity and/or quality ordered. Payment will be accomplished by submission

Initials: MS

Initials: 

of an invoice, with the contract number referenced thereon. Payment in advance of receipt of services and/or materials by the County cannot be made.

The invoice submitted shall be in sufficient detail as to item, quantity and price in order for the County to verify compliance with the awarded bid.

SECTION 3. Acceptance of Services and/or Materials

Receipt of services and/or materials shall not constitute acceptance. Final acceptance and authorization of payment shall be given only after a thorough inspection indicates that the services and/or materials meet bid specifications and conditions. Should the quantity and/or quality differ in any respect from specifications, payment will be withheld until such time as the Vendor takes necessary corrective action. If the proposed corrective action is not acceptable to the County, the County Manager's Office may authorize the recipient to refuse final acceptance of the quantity and/or quality received. Should a representative of the County agree to accept the services and/or materials on condition that the Vendor will correct their performance within a stipulated time period, then payment will be withheld until said corrections are made.

SECTION 4. Firm Prices

Prices for services and/or materials covered in the specifications of this Contract shall remain firm for the period of this Contract pursuant to pricing as reflected in Attachment "A"; net delivered to the ordering agency, **F.O.B. DESTINATION**. No additional fees or charges shall be accepted.

SECTION 5. Fund Availability

This Contract is deemed effective only to the extent that appropriations are available. Pursuant to Florida Statutes all appropriations lapse at the end of the Fiscal Year. Multi-year awards may be adequately funded but the County reserves the right not to appropriate for an ongoing procurement if it is deemed in its best interest.

SECTION 6. Expenses

Vendor shall be responsible for all expenses incurred while performing the services under this Contract. This includes, without limitation, license fees, memberships and dues; automobile and other travel expenses; meals and entertainment; insurance premiums; and all salary, expenses and other compensation paid to Vendor's agents, if any, hired by Vendor to complete the work under this Contract.

SECTION 7. Taxes

Initials: MS

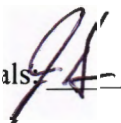
Initials: 

The County is tax exempt. As such, the County will not pay any Federal Excise or State of Florida Sales Tax. The Vendor will refrain from including taxes in any billing.

SECTION 8. Laws Governing this Contract

This Contract shall be consistent with, and be governed by, the Ordinances of Nassau County, the whole laws and rules of the State of Florida, both procedural and substantive, and applicable federal statutes, rules and regulations. Any and all litigation arising under this Contract shall be brought in Nassau County, Florida. Any mediation, pursuant to litigation, shall occur in Nassau County, Florida.

SECTION 9. Changes

The County reserves the right to order, in writing, changes in the work within the scope of the Contract, such as change in quantity or delivery schedule. The Vendor has the right to request an equitable price adjustment in cases where changes to the Contract under the authority of this clause result in increased costs to the Vendor.

SECTION 10. Modifications

In addition to modifications made under the changes clause, this Contract may be modified within the scope of the Contract upon the written and mutual consent of both parties, and approval by appropriate legal authority in the County.

SECTION 11. Assignment & Subcontracting

The Vendor will not be permitted to assign its Contract with the County, or to subcontract any of the work requirements to be performed without obtaining prior written approval by the County.

SECTION 12. Severability

If any section, subsection, sentence, clause, phrase, or portion of this Contract is, for any reason, held invalid, unconstitutional, or unenforceable by any Court of Competent Jurisdiction, such portion shall be deemed as a separate, distinct, and independent provision, and such holding shall not affect the validity of the remaining portions thereof.

SECTION 13. Termination for Default

The performance of the Contract may be terminated by the County in accordance with this clause, in whole or in part, in writing, whenever the County shall determine that the Vendor has failed to meet the requirements as outlined in this Contract.

SECTION 14. Termination for Convenience

Initials: MS

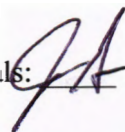
Initials: 

The County reserves the right to terminate the Contract in whole or part by giving the Vendor written notice at least thirty (30) days prior to the effective date of the termination. Upon receipt of written notice of termination from the County, the Vendor shall only provide those services and/or materials specifically approved or directed by the County. All other rights and duties of the parties under the Contract shall continue during such notice period, and the County shall continue to be responsible to the Vendor for the payment of any obligations to the extent such responsibility has not been excused by breach or default of the Vendor.

SECTION 15. Force Majeure

Neither party of this Contract shall be liable to the other for any cost or damages if the failure to perform the Contract arises out of causes beyond the control and without the fault or negligence of the parties. Such causes may include, but are not restricted to, acts of nature, fires, quarantine restriction, strikes and freight embargoes. In all cases, the failure to perform must be totally beyond the control and without any fault or negligence of the party.

SECTION 16. Access and Audits

The Vendor shall maintain adequate records to justify all charges, expenses, and costs incurred in providing the services and materials for at least three (3) years after completion of this Contract. The County and the Clerk of Courts shall have access to such books, records, and documents as required in this Section for the purpose of inspection or audit during normal business hours, at the County's or the Clerk's cost, upon five (5) days' written notice.

SECTION 17. Vendor Responsibilities

The Vendor will provide the services and materials agreed upon in a timely and professional manner in accordance with specifications referenced herein and in accordance with the *Technical Specifications/Scope of Work*.

SECTION 18. Public Emergencies

The Vendor shall agree before, during, and after a public emergency, disaster, hurricane, tornado, flood, or other acts of nature that the County shall require a "First Priority" for services and materials. It is vital and imperative that the majority of citizens are protected from any emergency situation that threatens public health and safety, as determined by the County. The Vendor agrees to sell all materials to and perform all services for the County or governmental entities on a "First Priority" basis. The County expects to pay a fair and reasonable price for all services and materials rendered or contracted in the event of a disaster, emergency, hurricane, tornado or other acts of nature.

Initials: MS

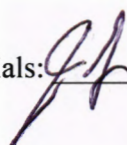
Initials: 

SECTION 19. Period of Contract/Option to Extend or Renew

The performance period of this Contract shall begin upon full execution by the last party to execute this Contract and terminate in 180 days thereafter. Any extensions shall be signed and approved by both parties. Any Contract or amendment to the Contract shall be subject to fund availability and mutual written agreement between the County and the Vendor.

SECTION 20. Probationary Period

The first ninety (90) days of this Contract are to be considered a “probationary” period. At the County’s election, this Contract may be terminated, based on the performance of the Vendor, and a new award be granted without another formal bid.

SECTION 21. Independent Vendor Status

Vendor and County agree that: (a) Vendor has the right to perform services for others during the term of this Contract; (b) Vendor has the sole right to control and direct the means, manner and method by which the services required by this Contract will be performed; (c) Vendor has the right to perform the services required by this Contract at any location or time; (d) Vendor has the right to hire assistants as subcontractors, or to use employees to provide the services required by this Contract.

SECTION 22. Indemnification and Insurance

Vendor shall indemnify and hold harmless County and its agents and employees from liabilities, damages, losses and costs, including but not limited to, reasonable attorney’s fees, to the extent caused by the negligence, recklessness, or intentionally wrongful conduct of Vendor and any persons employed or utilized by Vendor, in the performance of the Contract.

Vendor shall maintain such commercial (occurrence form) or comprehensive general liability, workers compensation, professional liability, and other insurance as is detailed in Exhibit “1” and as is appropriate for the goods or services being performed hereunder by Vendor, its employees or agents.

SECTION 23. Dispute Resolution

The County may utilize this section, at their discretion, as to disputes regarding Contract interpretation. The County may send a written communication to the Vendor by email, overnight mail, UPS, FedEx, or certified mail. The written notification shall set forth the County’s interpretation of the Contract. A response shall be provided in the same manner prior to the initial meeting with the County Manager. This initial meeting shall take place no more than twenty (20)

Initials: MS

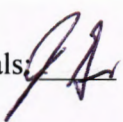
Initials: 

days from the written notification of the dispute addressed to the Vendor. The Vendor should have a representative, at the meeting that can render a decision on behalf of the Vendor.

If there is no satisfactory resolution as to the interpretation of the contract, the dispute may be submitted to mediation in accordance with mediation rules as established by the Florida Supreme Court. Mediators shall be chosen by the County and the cost of mediation shall be borne by the Vendor. The Vendor shall not stop work during the pendency of mediation or dispute resolution.

SECTION 24. E-Verify System

Vendor must comply with F.S. 448.095 and use the United States Department of Homeland Security's E-Verify system ("E-Verify") to verify the employment eligibility of all persons hired by Vendor during the term of this Agreement to work in Florida. Additionally, if Vendor uses subcontractors to perform any portion of the Work (under this Agreement), Vendor must include a requirement in the subcontractor's contract that the subcontractor use E-Verify to verify the employment eligibility of all persons hired by subcontractor to perform any such portion of the Work. Answers to questions regarding E-Verify as well as instructions on enrollment may be found at the E-Verify website: www.uscis.gov/e-verify.

SECTION 25. Public Records

The County is a public agency subject to Chapter 119, Florida Statutes. IF THE VENDOR HAS QUESTIONS REGARDING THE APPLICATION OF CHAPTER 119, FLORIDA STATUTES, TO THE VENDOR'S DUTY TO PROVIDE PUBLIC RECORDS RELATING TO THIS CONTRACT, CONTACT THE CUSTODIAN OF PUBLIC RECORDS AT (904) 530-6010, RECORDS@NASSAUCOUNTYFL.COM, 96135 NASSAU PLACE, YULEE, FLORIDA 32097. Under this agreement, to the extent that the Vendor is providing services to the County, and pursuant to section 119.0701, Florida Statutes, the Vendor shall:

- a. Keep and maintain public records required by the public agency to perform the service.
- b. Upon request from the public agency's custodian of public records, provide the public agency with a copy of the requested records or allow the records to be inspected or copied within a reasonable time at a cost that does not exceed the cost provided in this chapter or as otherwise provided by law.
- c. Ensure that public records that are exempt or confidential and exempt from public

Initials: MS

Initials: JA

records disclosure requirements are not disclosed except as authorized by law for the duration of the Contract term and following completion of the Contract if the Vendor does not transfer the records to the public agency.

d. Upon completion of the Contract, transfer, at no cost, to the public agency all public records in possession of the Vendor or keep and maintain public records required by the public agency to perform the service. If the Vendor transfers all public records to the public agency upon completion of the Contract, the Vendor shall destroy any duplicate public records that are exempt or confidential and exempt from public records disclosure requirements. If the Vendor keeps and maintains public records upon completion of the Contract, the Vendor shall meet all applicable requirements for retaining public records. All records stored electronically must be provided to the public agency, upon request from the public agency's custodian of public records, in a format that is compatible with the information technology systems of the public agency.

SECTION 26. Request for Records; Noncompliance

A request to inspect or copy public records relating to a public agency's contract for materials must be made directly to the public agency. If the public agency does not possess the requested records, the public agency shall immediately notify the Vendor of the request, and the Vendor must provide the records to the public agency or allow the records to be inspected or copied within a reasonable time.

If a Vendor does not comply with the public agency's request for records, the public agency shall enforce the Contract provisions in accordance with the Contract.

A Vendor who fails to provide the public records to the public agency within a reasonable time may be subject to penalties under §119.10, Florida Statutes.

SECTION 27. Civil Action

If a civil action is filed against the Vendor to compel production of public records relating to the Contract, the Court shall assess and award against the Vendor the reasonable costs of enforcement, including reasonable attorney fees if:

- (a) The Court determines that the Vendor unlawfully refused to comply with the public records request within a reasonable time; and
- (b) At least eight (8) business days before filing the action, the plaintiff provided written notice of the public records request, including a statement that the Vendor has not complied with the request, the public agency and to the Vendor.

Initials: MS

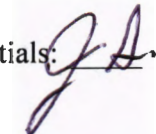
Initials: 

A notice complies with subparagraph (b), if it is sent to the public agency's custodian of public records and to the Vendor at the Vendor's address listed on its Contract with the public agency or to the Vendor's registered agent. Such notices must be sent by common carrier delivery service or by registered, Global Express Guaranteed, or certified mail, with postage or shipping paid by the sender and with evidence of delivery, which may be in an electronic format.

A Vendor who complies with a public records request within eight (8) business days after the notice is sent is not liable for the reasonable costs of enforcement.

SECTION 28. Disclosure of Litigation, Investigations, Arbitration or Administrative Decisions

The Vendor, during the term of this Contract, or any extension, has a continual duty to properly disclose to the County Attorney, in writing, upon occurrence, all civil or criminal litigation, arbitration, mediation, or administrative proceeding involving the Vendor. If the existence of the proceeding causes the County concerns that the Vendor's ability or willingness to perform this contract is jeopardized, the Vendor may be required to provide the County with reasonable written assurance to demonstrate the Vendor can perform the terms and conditions of the Contract.

SECTION 29. Entire Agreement

The written terms and provisions of this Contract shall supersede all prior verbal statements of any official or other representative of the County. Such statements shall not be effective or be construed as entering into, or forming a part of, or altering in any manner whatsoever, this Contract or Contract Documents.

IN WITNESS WHEREOF, the parties have executed this Contract which shall be deemed an original on this day and year first above written.

Initials: MS

Initials: JA

**BOARD OF COUNTY COMMISSIONERS
NASSAU COUNTY, FLORIDA**

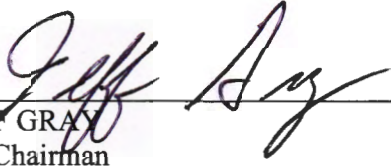

JEFF GRAY
Its: Chairman
Date: August 24, 2020

Attest as to authenticity of the
Chair's signature:

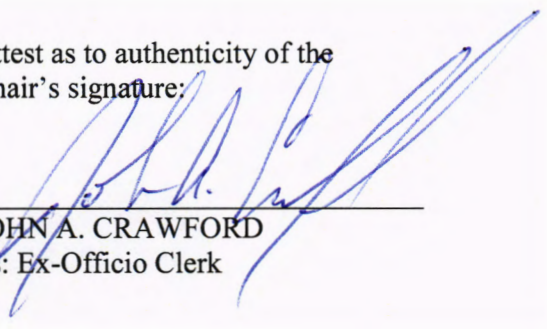

JOHN A. CRAWFORD
Its: Ex-Officio Clerk

Approved as to form and legality by the
Nassau County Attorney

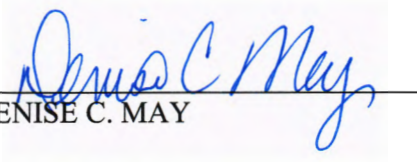

DENISE C. MAY

**MCS MECHANICAL CONTRACTOR
INC.**

Michael Shott

By: Michael Shott

Its: President

Date: 7/14/2022

Initials: _____

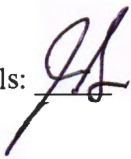
Initials: 



INVITATION TO BID

NASSAU COUNTY BOARD OF COUNTY COMMISSIONERS

Solicitation Title: NCSO Mechanics Garage Outside Air System / Foam Insulation	
Solicitation Number: NC22-007-ITB	Project/Contract Duration: 90 days after contract execution
Requesting Department: Facilities Maintenance	Procurement Contact: Evelyn Burton
Contact Address: 45195 Musselwhite Rd Callahan, FL 32011	Contact Information: eburton@nassaucountyfl.com procurement@nassaucountyfl.com
Response Due Date and Opening Date/Time: Thursday, March 24, 2022 @ 10:00 AM (Nassau County time)	
MANDATORY Pre-Bid Meeting March 10, 2022 - 9:30 AM NC Sheriff's Office – Mechanics Garage 77151 Citizens Circle, Yulee, FL 32097	Deadline for Questions: March 17, 2022 @ 4:00 PM
Location of Response Opening: Robert M. Foster Justice Center, 76347 Veterans Way, Second Floor, Yulee, Florida 32097	

In accordance with the intent and content of this solicitation, we the undersigned do hereby offer to perform as stipulated in this response. Failure to do so may result in the forfeiting of bid security, removal from the County's vendor list, or other remedies available to the County under the laws of the State of Florida.

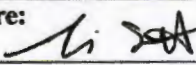
Legal Name of Respondent: mcs mechanical Contractor Inc.		
Business Address: 3081 Barbara lane Hilliard, FL 32046		
Phone Number: 904-545-0929	Email: mcsmechanical@windstream.net	FL License Number:
Authorized Signature: 		Date: 4/5/2022
Printed Name of Signer: Michael Shott		Title: President

General Instructions/Declarations

1. Response results will be available pursuant to Florida Statute 119.071(b).
2. Responses must be submitted on the forms furnished by the County within this solicitation, unless otherwise specified below.
3. This page must be completed and returned as the top sheet of any response submitted.
4. It is the intent and purpose of Nassau County that this solicitation promotes competitive bidding. It shall be the Responder's responsibility to advise the Procurement Department via the County's electronic bidding platform if, in the Responder's opinion, any language, requirements, etc. inadvertently restricts or limits competition. Such notification must be submitted via the County's electronic bidding platform and must be received by the Procurement Department no later than the Deadline for Questions date and time stated above.

(THIS PAGE MUST BE RETURNED WITH YOUR RESPONSE)

NASSAU COUNTY INVITATION TO BID
NC22-007 – NCSO MECHANICS GARAGE OUTSIDE AIR SYTEMS/ FOAM INSULATION

RESPONSE PRICE SHEET

Description	Lump Sum Price
Turnkey project: Provide lump sum price per Scope of Work to include all labor, equipment, material & fees to install the outside air split systems and spray foam insulation at the Nassau County Sheriff's Office Mechanics Garage	\$ <u>198,733.00</u>

One Hundred Ninety Eight Thousand and Seven Hundred Thirty Three Dollars
(Price in words)

The undersigned declares that they have examined the Notice to Bidders, Instructions to Bidders, and Technical Specifications/Scope of Work and is informed fully with regard to all terms and conditions pertaining thereto and agrees under these specifications at the prices set forth above.

Company: MCS Mechanical Contractor Inc.

Address: 3081 Barbara lane

City, State, Zip: Hilliard, FL 32046

By: [Signature]

(Signature)

Michael Shott

(Above name printed or typed)

Phone #: 904-545-0929

E-mail: mcsmechanical@windstream.net

NCO Mechanics Garage

(1) Above Air Outside Air Split System, each complete with:

- Unit Tag(s): OA-1
- Model: HKE-144D-4-HGHP0-00-OA-1D-EC-00-RT-C_XP4-144D-8-00-OA-00-VF-FV
- Heat pump configuration
- DX Split Evaporator (Compressor with Evaporator)
- Dual Scroll Compressors - 1st Circuit Digital; 2nd Circuit Fixed Spd
- DX Air-Cooled, Outdoor Remote (Compressor w/ Evaporator)
- Hot Gas Reheat (MOD, 1-Row)
- 21.0 to 25.0 kW Electric Heater (Duct mounted post heat)
- Advanced Microprocessor Controller
- BMS Connection - BACnet Over MS/TP
- No CO2 Sensor Selected
- Low Ambient Variable Speed Fan Head Pressure Control
- 460/3/60 electric power at evaporator – non-fused disconnect shipped loose
- 277/1/60 electric power at remote condenser – non-fused disconnect shipped loose
- 1-year limited parts, warranty provided by Above Air per their standard terms and condition
- Factory Start Up is NOT INCLUDED. Above Air has options for startup assistance via telephone.



Submittal Data Sheet
HK-OA™ Horizontal AC Equipment

1 of 2
3/30/2022 Rev 2

Unit Tag	OA-1	Project	Nassau County Mechanics Garage
Evap Model, Qty (1)	HKE-144D-4-HGHP0-00-OA-1D-EC-00-RT-C	Engineer	Powell and Hinkle
Cond Model, Qty (1)	XP4-144D-8-00-OA-00-VF-FV	Contractor	TBD
Unit Type	12.0 Ton (Dual Circuit) Nom. HK-OA ACU w/ Split Condenser	AboveAir Rep Date	Brooks (Stewart Galligher) 30-Mar-22

Electrical Data

Evap Section Power	460-480/3/60
Evap Nameplate	28.3 FLA 31.1 MCA 40 MOP
Cond Section Power	460-480/1/60
Cond Nameplate	8.0 FLA 10.0 MCA 15 MOP

Design Ambient Conditions

Summer	95.0°F DB / 78.0°F WB
Winter	21.0°F DB

Design Space Conditions

Cooling	75.0°F DB / 62.5°F WB
Heating	75.0°F DB

Supply Air Fan Data

Total Airflow Rate	1,950 cfm
Outdoor Airflow Rate	1,950 cfm OA / 100.0%
ESP / TSP	2.00 in w.g. / 2.40 in w.g.
Fan Type, Qty (1)	ECM Direct Drive BI Impeller
Motor kW / FLA (Each)	4.4 kW / 5.9 FLA
Fan Speed Control	Constant Speed

Cooling Coil Data

Gross Capacity	167.9 TMBh / 87.8 SMBh
Net Capacity	164.2 TMBh / 84.1 SMBh
Mixed EAT	95.0°F DB / 78.0°F WB
Coil LAT	53.6°F DB / 52.9°F WB
Condensate Flow	75.4 lb/hr
Face Area / Rows / FPI	8.3 ft ² / 6 / 12
Construction	Aluminum Finned, Copper Tube

Hot Gas Reheat Coil Data

Capacity	42.5 MBh
LAT (@ Max Output)	73.6°F DB / 60.6°F WB
Face Area / Rows / FPI	7.7 ft ² / 1 / 12
Construction	Aluminum Finned, Copper Tube
Control	Modulating

Compressor Data

Comp 1 Type	Digital Scroll
Comp 1 LRA / RLA	75.0 LRA / 11.2 RLA
Comp 2 Type	Fixed Speed Scroll
Comp 2 LRA / RLA	75.0 LRA / 11.2 RLA
Location	Evaporator Section
Refrigerant Type	R-410a

Condenser Data

Total Heat of Rej.	206.3 MBh
Coil Construction	Aluminum Finned, Copper Tube
Airflow	13,000 cfm @ 0.00 in w.g. ESP
Fan Type, Qty 4	Axial Fan
Low Ambient Control	Variable Speed Fan (-20°F)
Motor HP / FLA (each)	1/3 HP / 1.0 FLA

Heat Pump Data

Capacity at 47°F	151.1 MBh
EAT / LAT	47.0°F / 118.3°F
Capacity at 17°F	84.0 MBh
EAT / LAT	17.0°F / 56.6°F

Duct Mounted Electric Pre-Heat Data

Type	N/A
Capacity / FLA	N/A
EAT / LAT	N/A
Duct Dimensions	N/A
Power Connections	N/A

Unit Mounted Heat Data

Type	N/A
Capacity / FLA	N/A
Operation	N/A
EAT / LAT	N/A
EWT / LWT	N/A
GPM @ Ft Hd	N/A
Fluid	N/A
Face Area / Rows / FPI	N/A
Construction	N/A
Control Valve	N/A
Control Valve Cv	N/A

Duct Mounted Post Heat Data

Type	SCR Electric Heat
Capacity / FLA	25 kW / 31.4 FLA
Operation	Heat Only
EAT / LAT	21.0°F / 61.2°F
Turndown	N/A
Min/Max Pressures	N/A
Duct Dimensions	Please Advise, 1,200 FPM Max
Power Connections	Powered Separately

www.aboveair.com
sales@aboveair.com

AboveAir Technologies
5179 Mountville Road
Frederick, Maryland 21703 USA

Ph: 301-874-1130
Fax: 301-874-1131



Submittal Data Sheet
HK-OA™ Horizontal AC Equipment

2 of 2
3/30/2022 Rev 2

Unit Configuration & Airflow Patterns

- Straight-Thru (RLST) Ducted AC Unit
- Outdoor Split Condenser

Refrigerant Field Connections

Indoor Unit (Qty 2 ea.) 1/2" OD Liq & 3/4" OD Discharge
Indoor HG Reheat N/A
Outdoor Unit (Qty 2 ea.) 1/2" OD Liq & 7/8" OD Discharge
Outdoor HG Reheat N/A

Connection Data

Condensate Drain 3/4" FPT

Air Filtration Data

Filter Qty (3) 16x25 (2" MERV 8)

Physical Data

Dimensions See attached cut sheet
Evap / Cond Weight 1100 lb / 955 lb

System Notes

1. System ships with a dry nitrogen charge.
2. Do not install refrigerant piping based upon connection sizes. Refrigerant piping runs must be sized according to piping requirements at www.aboveairloms.com.
3. Max total equivalent line length is 150 feet.

Coil Coatings

- Supply Air Coils - Heresite
- Condenser Coil - Heresite

Factory Installed Optional Accessories

- Receiver (Circuit 1)
- Suction Line Accumulator (per Compressor)

Field Installed Optional Accessories

- Non-Fused Disconnect (Cond & Evap Section)

Control Type

- MC-Series Advanced Microprocessor w/ Alarms

Control Sequence

- MC-3000P RH HPOA DX Primary Temp & Humidity Control

Sensors & Displays

- Remote Mtd Human Machine Interface (HMI) & 50' Cable
- Duct Mounted Mixed Air Temp & Humidity Sensor
- Duct Mounted Supply Air Temperature Sensor
- Wall Mounted Temperature & Humidity Sensor

Control Options

- BMS Card (BACnet MSTP)

Factory Warranties (Labor Not Included)

- 1 Year Limited Parts Warranty

Select Standard Design Features

- Heavy Duty Gavanneal Steel Construction
- High Efficiency Scroll Compressor
- TXV with External Equilization
- High & Low Refrigerant Pressure Safety Switches
- Stainless Steel Drain Pan with Overflow Safety Switch
- Intertek (ETL) UL STD 1995 Listed/Labeled
- Factory installed and tested controls
- Each unit factory tested per UL 1995 Requirements

Additional Recommended Accessories

- Compressor Sound Jacket (per Compressor)
- Voltage/Phase Monitor(Cond & Evap Section)
- Air-Side Economizer - Field Installed Mixing Box
- Duct Mtd Firestat
- Duct Mtd Smoke Detector
- Water Detector (Probe/Spot Type)
- Hanging Spring Vibration Isolators (Evap Section)
- Med Capacity Condensate Pump (Power thru Unit)
- Neoprene Vibration Isolators (Cond Section)

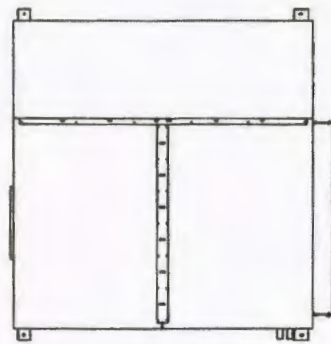

Top View

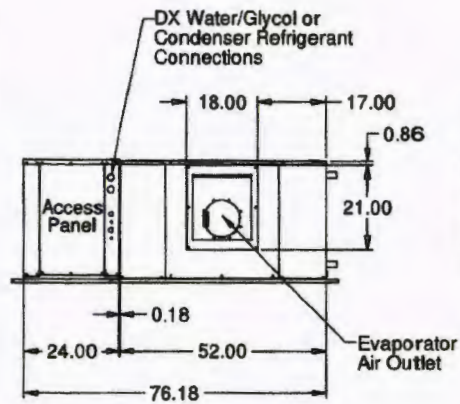
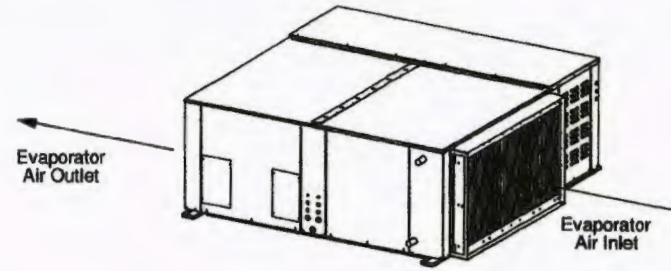

Left View

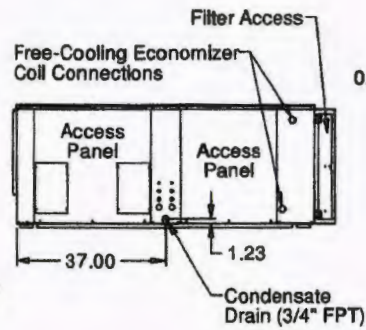

Front View

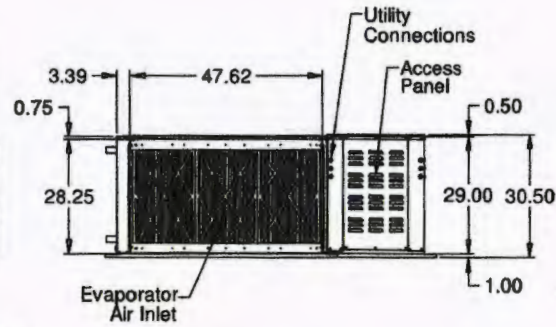

Right View

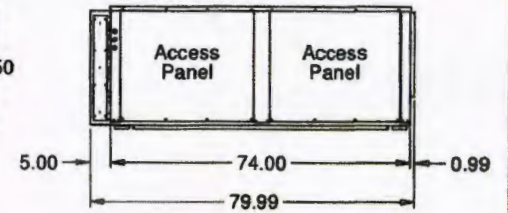

Rear View

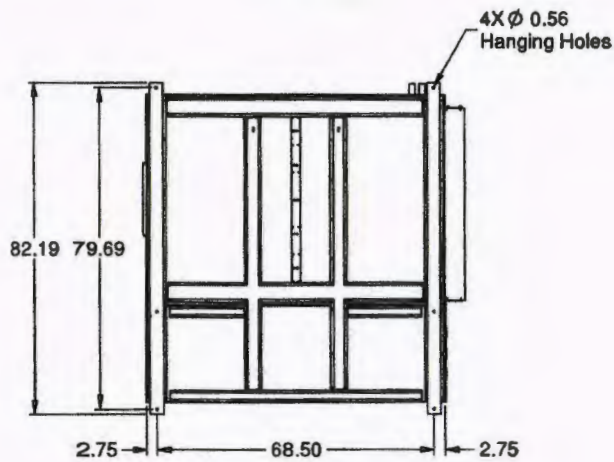

Bottom View

	Dwg No. MD2341-0025	
	Date 7/13/21	Rev -
Tel: (301) 874-1130		
Description		
HK Large S-T V2 Packaged W/G SW R-L Impeller		

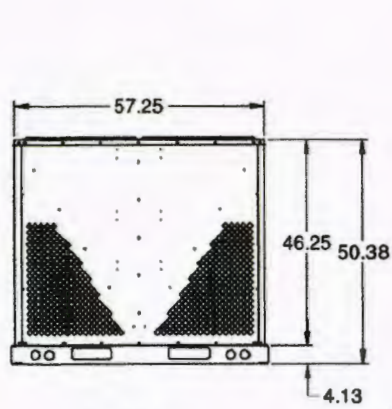
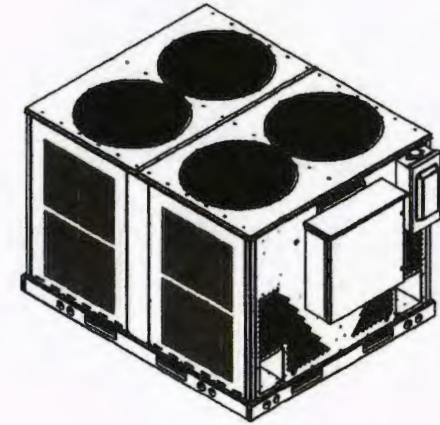
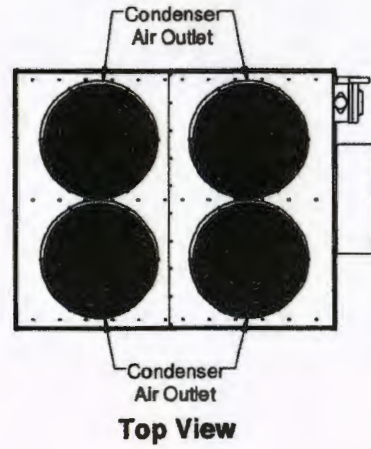

Left View

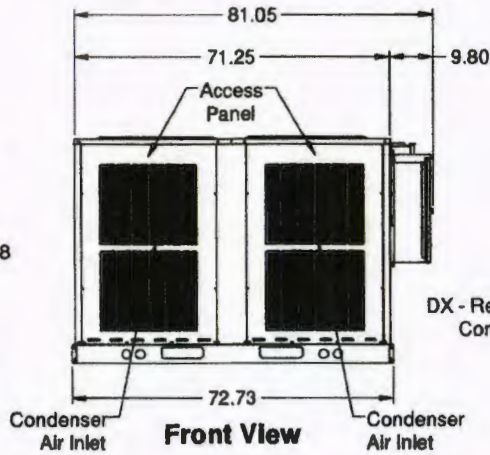

Front View

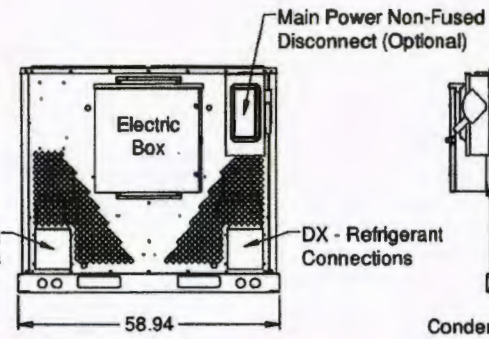

Right View

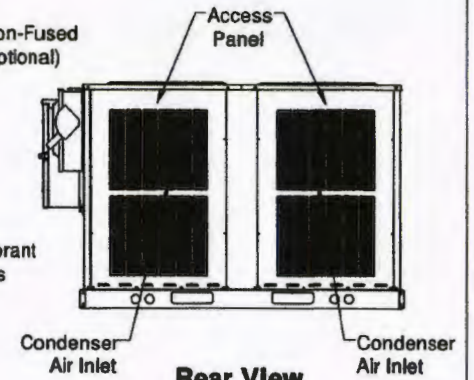

Rear View

 Tel: (301) 874-1130	Dwg No. MD3356-1-0001	
	Date 6/29/21	Rev D
Description XPU-XP4 15-20T Outdoor Propeller Fans		

NASSAU COUNTY INVITATION TO BID
NC22-007 – NCSO MECHANICS GARAGE OUTSIDE AIR SYTEMS/ FOAM INSULATION

ATTACHMENT "D"
ADDENDA ACKNOWLEDGMENT

<p>Acknowledgment is hereby made of receipt of addenda issued during the solicitation period.</p> <p>SOLICITATION NUMBER: NC22-007-ITB</p>	<p>Addendum # <u>1</u> through # <u>3</u></p> <p>Date: <u>4/5/2022</u></p>
<p>Signature of Person Completing:</p> <p><i>M. Shott</i></p>	
<p>Printed Name:</p> <p>Michael Shott</p>	<p>Title:</p> <p>President</p>

>>>Failure to submit this form may disqualify your response<<<

NASSAU COUNTY INVITATION TO BID
NC22-007 – NCSO MECHANICS GARAGE OUTSIDE AIR SYTEMS/ FOAM INSULATION

**ATTACHMENT “E”
SWORN STATEMENT
UNDER FLORIDA STATUTE 287.133(3)(a) ON PUBLIC ENTITY CRIMES**

TO BE RETURNED WITH BID

THIS MUST BE SIGNED IN THE PRESENCE OF A NOTARY PUBLIC OR OTHER OFFICER AUTHORIZED TO ADMINISTER OATHS

1. This sworn statement is submitted with Bid, Proposal or Contract for MCS Mechanical Contractor Inc.
2. This sworn statement is submitted by mcs mechanical Inc. (entity submitting sworn statement), whose business address is 3081 Barbara lane Hilliard FL 32046 and its Federal Employee Identification Number (FEIN) is 59-3552495. (If the entity has no FEIN, include the Social Security Number of the individual signing this sworn statement: _____.)
3. My name is Michael Shott (please print name of individual signing), and my relationship to the entity named above is President.
4. I understand that a “public entity crime” as defined in Paragraph 287.133(1)(g), Florida Statutes, means a violation of any state or federal law by a person with respect to and directly related to the transaction of business with any public entity or with an agency or political subdivision of any other state or with the United States, including, but not limited to, any bid or contract for goods or services, any leases for real property, or any contract for the construction or repair of a public building or public work, to be provided to any public entity or an agency or political subdivision of any other state or of the United States and involving antitrust, fraud, theft, bribery, collusion, racketeering, conspiracy, or material misrepresentation.
5. I understand that “convicted” or “conviction” as defined in paragraph 287.133(1)(b), Florida Statutes, means a finding of guilt or a conviction or a public entity crime, with or without an adjudication of guilt, in any federal or state trial court of record relating to charges brought by indictment or information after July 1, 1989, as a result of a jury verdict, non-jury trial, or entry of a plea of guilty or nolo contendere.
6. I understand that an “affiliate” as defined in paragraph 287.133(1)(a), Florida Statutes, means:
 - a) A predecessor or successor of a person convicted of a public entity crime; or
 - b) An entity under the control of any natural person who is active in the management of the entity and who has been convicted of a public entity crime. The term “affiliate” includes those officers, directors, executives, partners, shareholders, employees, members, and agents who are active in the management of an affiliate. The ownership by one person of shares constituting a controlling interest in another person, or a pooling of equipment or income among persons when not to fair market value under an arm’s length agreement, shall be prima facie case that one person controls another person. A person who knowingly enters into a joint venture with a person who has been convicted of a public entity crime in Florida during the preceding thirty-six (36) months shall be considered an affiliate.
7. I understand that a “person” as defined in Paragraph 287.133(1)(e), Florida Statutes, means any natural person or entity organized under the laws of any state or of the United States with the legal power to enter into binding contract and which bids or applies to bid on contracts let by a public entity, or which otherwise transacts or applies to transact business with a public entity. The term “person” includes those officers, directors, executives, partners, shareholders, employees, members, and agents who are active in management of an entity.
8. Based on information and belief, the statement, which I have marked below, is true in relation to the entity submitting this sworn statement. (Please indicate which statement applies.)

NASSAU COUNTY INVITATION TO BID
NC22-007 – NCSO MECHANICS GARAGE OUTSIDE AIR SYTEMS/ FOAM INSULATION

Neither the entity submitting this sworn statement, nor any of its officers, directors, executives, partners, shareholders, employees, members, or agents who are active in management of the entity, nor any affiliate of the entity have been charged with and convicted of a public entity crime subsequent to July 1, 1989.

The entity submitting this sworn statement, or one of more of the officers, directors, executives, partners, shareholders, employees, members, or agents who are active in management of the entity, or an affiliate of the entity has been charged with and convicted of a public entity crime subsequent to July 1, 1989, and (Please indicate which additional statement applies.)

There has been a proceeding concerning the conviction before a hearing officer of the State of Florida, Division of Administrative Hearings. The final order entered by the Hearing Officer did not place the person or affiliate on the convicted vendor list. (Please attach a copy of the final order.)

The person or affiliate was placed on the convicted vendor list. There has been a subsequent proceeding before a hearing officer of the State of Florida, Division of Administrative Hearings. The final order entered by the hearing officer determined that it was in the public interest to remove the person or affiliate from the convicted vendor list. (Please attach a copy of the final order.)

The person or affiliate has not been placed on the convicted vendor list. (Please describe any action taken by or pending with the Department of General Services.)

[Signature]
Signature
4/5/2022
Date

State of: Florida
County of: Nassau

Sworn to (or affirmed) and subscribed before me by means of physical presence or online notarization, this 5th day of April, 2022 by Michael Stott who is personally known to me or produced _____ as identification.



Kelly Stott
Notary Public
My commission expires: 5/25/2025

NASSAU COUNTY INVITATION TO BID
NC22-007 – NCSO MECHANICS GARAGE OUTSIDE AIR SYTEMS/ FOAM INSULATION

State of: Florida

County of: Nassau

The preceding was sworn to (or affirmed) and subscribed before me by means of physical presence or online notarization, this 5th day of April, 2022 by Michael Shott who is personally known to me or produced _____ as identification.



Kelly Shott
Notary Public

My commission expires: 5/25/2025

**NASSAU COUNTY INVITATION TO BID
NC22-007 – NCSO MECHANICS GARAGE OUTSIDE AIR SYTEMS/ FOAM INSULATION**

**ATTACHMENT "F"
EXPERIENCE OF BIDDER**

The following questionnaire shall be answered by the bidder for use in evaluating the bid to determine the lowest, responsive, and responsible bidder, meeting the required specifications.

1. **FIRM NAME:** mcs mechanical Inc.
Address: 3081 Barbara lane
City/State/Zip: Hilliard, FL 32046
Phone: 904-545-0929 **Email:** mcsmechanical@windstream.net
Name of primary contact responsible for work performance: mike shott
Phone: 904-545-0929 **Cell Phone:** _____
Email: _____
2. **INSURANCE:**
Surety Company: Nielson, Wojtowicz, Neu & Associates
Agent Company: Nielson Hoover Group
Agent Contact: Jessica Reno
Total Bonding Capacity: \$1,000,000 **Value of Work Presently Bonded:** \$418,755
3. **EXPERIENCE:**
Years in business: 23 years
Years in business under this name: 23 years
Years performing this type of work: 23 years
Value of work now under contract: 1,539,000
Value of work in place last year: _____
Percentage (%) of work usually self-performed: 85%
Name of subvendors you may use: White Electrical
Has your firm: Failed to complete a contract: ___ Yes No
Been involved in bankruptcy or reorganization: ___ Yes No
Pending judgment claims or suits against firm: ___ Yes No
4. **PERSONNEL**
How many employees does your company employ:
- | | | | | |
|-----------------------|----------|-----------|-----|-----------|
| Management | <u>2</u> | Full time | ___ | Part time |
| Site/Crew Supervisors | <u>2</u> | Full time | ___ | Part time |
| Workers/Laborers | <u>6</u> | Full time | ___ | Part time |
| Clerical | <u>1</u> | Full time | ___ | Part time |
| Other | ___ | Full time | ___ | Part time |

NASSAU COUNTY INVITATION TO BID
NC22-007 – NCSO MECHANICS GARAGE OUTSIDE AIR SYTEMS/ FOAM INSULATION

5. WORK EXPERIENCE:

List your three (3) most significant commercial accounts where the contract was similar in scope and size to this bid.

Reference #1:

Company/Agency Name: Snyder/Florida Department of military Affairs
 Address: 9900 Normandy Blvd Jacksonville, FL 32221
 Contact Person: Todd Andersen
 Phone: 904-823-0379 Email: michael.t.anderson34.nfg@army.mil
 Project Description: 100% Outside Air Units, Ductwork, Electrical, Concrete
 Contract \$ Amount: \$98,755.00
 Date Completed: 5/1/2020

Reference #2:

Company/Agency Name: Federal Aviation Administration
 Address: 37075 Aviation Lane Hilliard, FL 32046
 Contact Person: Charles Plumb
 Phone: 804-938-2813 Email: Cplumb@greenlandenterprises.com
 Project Description: Chillers, Hydronic piping, Electrical, Automation, Abatement
 Contract \$ Amount: \$393,346.00
 Date Completed: 3/1/2019

Reference #3:

Company/Agency Name: Florida Department of military Affairs
 Address: 190 San Marco St Augustine, FL 32084
 Contact Person: 904-823-0316 John Trendler
 Phone: 904-823-0316 Email: John.w.Trendler.nfg@army.mil
 Project Description: Outdoor modulating OA/RA Unit, Duct work, Electrical, Controls
 Contract \$ Amount: \$134,755.00
 Date Completed: 4/5/2022

REMINDER:

THIS FORM IS TO BE INCLUDED WITH BID. FAILURE TO SUBMIT ALONG WITH BID MAY BE CAUSE FOR DISQUALIFICATION.

NASSAU COUNTY INVITATION TO BID
NC22-007 – NCSO MECHANICS GARAGE OUTSIDE AIR SYTEMS/ FOAM INSULATION

ATTACHMENT "G"
DRUG FREE WORKPLACE CERTIFICATE

I, the undersigned, in accordance with Florida Statute 287.087, hereby certify that _____
MCS Mechanical Contractor Inc. (print or type name of firm):

1. Publishes a written statement notifying that the unlawful manufacture, distribution, dispensing, possession or use of a controlled substance in the workplace named above and specifying actions that will be taken against violations of such prohibition.
2. Informs employees about the dangers of drug abuse in the workplace, the firm's policy of maintaining a drug free working environment, and available drug counseling, rehabilitation, and employee assistance programs, and the penalties that may be imposed upon employees for drug use violations.
3. Gives each employee engaged in providing commodities or contractual services that are under bid or proposal, a copy of the statement specified above.
4. Notifies the employees that as a condition of working on the commodities or contractual services that are under bid or proposal, the employee will abide by the terms of the statement and will notify the employer of any conviction of, plea of guilty or nolo contendere to, any violation of Chapter 1893, or any controlled substance law of the State of Florida or the United States, for a violation occurring in the work place, no later than five (5) days after such conviction, and requires employees to sign copies of such written statement to acknowledge their receipt.
5. Imposes a sanction on, or requires the satisfactory participation in, a drug abuse assistance or rehabilitation program, if such is available in the employee's community, by any employee who is so convicted.
6. Makes a good faith effort to continue to maintain a drug free workplace through the implementation of a drug free workplace program.

"As a person authorized to sign a statement, I certify that the above-named business, firm, or corporation complies fully with the requirements set forth herein."

Authorized Signature

4/5/2022
Date Signed

Document A310™ – 2010

Conforms with The American Institute of Architects AIA Document 310

Bid Bond

CONTRACTOR:

(Name, legal status and address)

MCS Mechanical Contractor, Inc.
3081 Barbara Lane
Hilliard, FL 32046

OWNER:

(Name, legal status and address)

Nassau County, FL
76347 Veterans Way, Suite 456
Yulee, FL 32097

SURETY:

(Name, legal status and principal place of business)

Philadelphia Indemnity Insurance Company
One Bala Plaza, Suite 100
Bala Cynwyd, PA 19004-0950
Mailing Address for Notices
1000 Central Ave, Suite 200
St. Petersburg, FL 33705

This document has important legal consequences. Consultation with an attorney is encouraged with respect to its completion or modification.

Any singular reference to Contractor, Surety, Owner or other party shall be considered plural where applicable.

BOND AMOUNT: 5% Five Percent of Amount Bid

PROJECT:

(Name, location or address, and Project number, if any)

HVAC Equipment and Duct Work / 77151 Citizens Circle, Yulee, FL 32097

The Contractor and Surety are bound to the Owner in the amount set forth above, for the payment of which the Contractor and Surety bind themselves, their heirs, executors, administrators, successors and assigns, jointly and severally, as provided herein. The conditions of this Bond are such that if the Owner accepts the bid of the Contractor within the time specified in the bid documents, or within such time period as may be agreed to by the Owner and Contractor, and the Contractor either (1) enters into a contract with the Owner in accordance with the terms of such bid, and gives such bond or bonds as may be specified in the bidding or Contract Documents, with a surety admitted in the jurisdiction of the Project and otherwise acceptable to the Owner, for the faithful performance of such Contract and for the prompt payment of labor and material furnished in the prosecution thereof; or (2) pays to the Owner the difference, not to exceed the amount of this Bond, between the amount specified in said bid and such larger amount for which the Owner may in good faith contract with another party to perform the work covered by said bid, then this obligation shall be null and void, otherwise to remain in full force and effect. The Surety hereby waives any notice of an agreement between the Owner and Contractor to extend the time in which the Owner may accept the bid. Waiver of notice by the Surety shall not apply to any extension exceeding sixty (60) days in the aggregate beyond the time for acceptance of bids specified in the bid documents, and the Owner and Contractor shall obtain the Surety's consent for an extension beyond sixty (60) days.

If this Bond is issued in connection with a subcontractor's bid to a Contractor, the term Contractor in this Bond shall be deemed to be Subcontractor and the term Owner shall be deemed to be Contractor.

When this Bond has been furnished to comply with a statutory or other legal requirement in the location of the Project, any provision in this Bond conflicting with said statutory or legal requirement shall be deemed deleted herefrom and provisions conforming to such statutory or other legal requirement shall be deemed incorporated herein. When so furnished, the intent is that this Bond shall be construed as a statutory bond and not as a common law bond.

Signed and sealed this 8th day of April, 2022.

MCS Mechanical Contractor, Inc.

(Principal)

(Seal)

(Witness)

By:

(Title)

Philadelphia Indemnity Insurance Company

(Surety)

(Seal)

By:

(Title) Kevin R. Wojtowicz, Attorney-in-Fact

(Witness) Peter Alessi

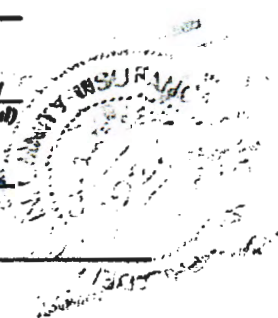

PHILADELPHIA INDEMNITY INSURANCE COMPANY

One Bala Plaza, Suite 100
Bala Cynwyd, PA 19004-0950

Power of Attorney

KNOW ALL PERSONS BY THESE PRESENTS: That PHILADELPHIA INDEMNITY INSURANCE COMPANY (the Company), a corporation organized and existing under the laws of the Commonwealth of Pennsylvania, does hereby constitute and appoint Kevin R. Weltowitz and Laura D. Mosholder of Nelson, Weltowitz, Neu & Associates, its true and lawful Attorney-in-fact with full authority to execute on its behalf bonds, undertakings, recognizances and other contracts of indemnity and writings obligatory in the nature thereof, issued in the course of its business and to bind the Company thereby, in an amount not to exceed \$50,000,000.

This Power of Attorney is granted and is signed and sealed by facsimile under and by the authority of the following Resolution adopted by the Board of Directors of PHILADELPHIA INDEMNITY INSURANCE COMPANY on the 14th of November, 2016.

RESOLVED: That the Board of Directors hereby authorizes the President or any Vice President of the Company: (1) Appoint Attorney(s) in Fact and authorize the Attorney(s) in Fact to execute on behalf of the Company bonds and undertakings, contracts of indemnity and other writings obligatory in the nature thereof and to attach the seal of the Company thereto; and (2) to remove, at any time, any such Attorney-in-Fact and revoke the authority given. And, be it

FURTHER RESOLVED: That the signatures of such officers and the seal of the Company may be affixed to any such Power of Attorney or certificate relating thereto by facsimile, and any such Power of Attorney so executed and certified by facsimile signatures and facsimile seal shall be valid and binding upon the Company in the future with respect to any bond or undertaking to which it is attached.

IN TESTIMONY WHEREOF, PHILADELPHIA INDEMNITY INSURANCE COMPANY HAS CAUSED THIS INSTRUMENT TO BE SIGNED AND ITS CORPORATE SEAL TO BE AFFIXED BY ITS AUTHORIZED OFFICE THIS 5TH DAY OF MARCH, 2021.



(Seal)

John Glomb, President & CEO
Philadelphia Indemnity Insurance Company

On this 5th day of March, 2021 before me came the individual who executed the preceding instrument, to me personally known, and being by me duly sworn said that he is the therein described and authorized officer of the PHILADELPHIA INDEMNITY INSURANCE COMPANY; that the seal affixed to said instrument is the Corporate seal of said Company; that the said Corporate Seal and his signature were duly affixed.

Notary Public:

Vanessa McKenzie

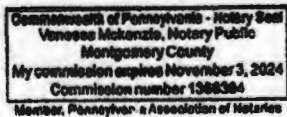

residing at:

Bala Cynwyd, PA

My commission expires:

November 3, 2024

I, Edward Sayago, Corporate Secretary of PHILADELPHIA INDEMNITY INSURANCE COMPANY, do hereby certify that the foregoing resolution of the Board of Directors and the Power of Attorney issued pursuant thereto on the 5th day March, 2021 are true and correct and are still in full force and effect. I do further certify that John Glomb, who executed the Power of Attorney as President, was on the date of execution of the attached Power of Attorney the duly elected President of PHILADELPHIA INDEMNITY INSURANCE COMPANY.

In Testimony Whereof I have subscribed my name and affixed the facsimile seal of each Company this 6 day of April, 2022



Edward Sayago, Corporate Secretary
PHILADELPHIA INDEMNITY INSURANCE COMPANY

ATTACHMENT "B"

Nassau County Sheriff's Office Mechanic Garage Outside Air System/Foam Insulation Project

Scope of Work

Nassau County is seeking a contractor to install outside air split systems and spray foam insulation at the Sheriff's Office Mechanic Garage located at 77151 Citizens Circle, Yulee, FL 32097.

Contractor to install:

- 1- Dedicated outside air split system model AEC144D-3HGES-00-0A-SF, R-410, 208/230/3-60volt (or equivalent), set in place on existing concrete equipment pad.
- 1- Above Air dedicated outside air split system model AEC144D-3HGES-00-0A-SF, R-410A, 208/230/3-60volt outdoor remote condensing unit (or equivalent), set in place on existing concrete equipment pad.
- Provide and install equipment stand for new outside air handler.
- Provide and install 28" x 48" wall penetration for OSA louver/ damper.
- Provide and install 6" round exterior wall penetration with wall sleeve for new refrigeration piping.
- Provide and install new Greenheck model EVH-501D 28"x48" louver with modulating damper (or equivalent).
- Install new sheet metal OSA duct between louver/damper and the outside air intake.
- Provide and install all necessary tubing, fittings, and hangers to properly run and connect refrigeration piping between outdoor condensing unit and indoor air handler sections.
- Make all solder joint connections with 15% silver solder, evacuate system and leak check all refrigeration piping connections.
- Install ¾ Armaflex (or equivalent) insulation on suction line piping including aluminum jacketing on all exterior piping.
- Provide and install new Sch 40 PVC pipe and fittings to run condensate line from indoor air handler to exterior of building.
- Provide and install Honeywell E3 gas monitor with controller and two CO sensors (or equivalent).
- Provide new electrical circuits as required for AHU and Condenser unit.
- Perform startup on equipment to check for proper operation and record operation data.
- Any lifts or other equipment needed to perform and complete the project, will need to be supplied by the contractor.

Spray Foam Insulation:

- Contractor will spray the underside of the roof deck of the mechanic garage, fire wall, office area with 3" closed cell foam and spray DC-315 Thermal Barrier over the foam.
 - The foam will need to have a finished look after being treated with Thermal Barrier (smooth finish).
 - Cover all equipment, tools, doors, and floor with 6mm & .5mm plastic.
-

This is a turnkey project and price should reflect P.E stamped designs (as required) and miscellaneous supplies not mentioned in the scope.

Accommodations will be made by the Sheriff's office to allow work to be performed during normal working hours, but after hour and weekend pricing should be listed as well.

[Expected Start Date: Once Purchase Order has been issued]

[Expected Completion Date: Within 90 days of contract being awarded]



CERTIFICATE OF LIABILITY INSURANCE

THIS CERTIFICATE IS ISSUED AS A MATTER OF INFORMATION ONLY AND CONFERS NO RIGHTS UPON THE CERTIFICATE HOLDER. THIS CERTIFICATE DOES NOT AFFIRMATIVELY OR NEGATIVELY AMEND, EXTEND OR ALTER THE COVERAGE AFFORDED BY THE POLICIES BELOW. THIS CERTIFICATE OF INSURANCE DOES NOT CONSTITUTE A CONTRACT BETWEEN THE ISSUING INSURER(S), AUTHORIZED REPRESENTATIVE OR PRODUCER, AND THE CERTIFICATE HOLDER.

IMPORTANT: If the certificate holder is an ADDITIONAL INSURED, the policy(ies) must have ADDITIONAL INSURED provisions or be endorsed. If SUBROGATION IS WAIVED, subject to the terms and conditions of the policy, certain policies may require an endorsement. A statement on this certificate does not confer rights to the certificate holder in lieu of such endorsement(s).

PRODUCER MIZELL INSURANCE AGENCY 11893 New Kings Rd Jacksonville, FL 32219	CONTACT NAME: PHONE (A/C, No, Ext): (904)764-3336 FAX (A/C, No): (904)764-2442 E-MAIL ADDRESS: larry@mizellins.com	
	INSURER(S) AFFORDING COVERAGE NAIC #	
INSURED MCS MECHANICAL CONTRACTOR, INC. 3081 BARBARA LANE HILLIARD, FL 32046	INSURER A : U.S. SPECIALTY INS CO 29599	
	INSURER B : F C B & I FUND	
	INSURER C :	
	INSURER D :	
	INSURER E :	

COVERAGES	CERTIFICATE NUMBER:	REVISION NUMBER:
------------------	----------------------------	-------------------------

THIS IS TO CERTIFY THAT THE POLICIES OF INSURANCE LISTED BELOW HAVE BEEN ISSUED TO THE INSURED NAMED ABOVE FOR THE POLICY PERIOD INDICATED. NOTWITHSTANDING ANY REQUIREMENT, TERM OR CONDITION OF ANY CONTRACT OR OTHER DOCUMENT WITH RESPECT TO WHICH THIS CERTIFICATE MAY BE ISSUED OR MAY PERTAIN, THE INSURANCE AFFORDED BY THE POLICIES DESCRIBED HEREIN IS SUBJECT TO ALL THE TERMS, EXCLUSIONS AND CONDITIONS OF SUCH POLICIES. LIMITS SHOWN MAY HAVE BEEN REDUCED BY PAID CLAIMS.

INSR LTR	TYPE OF INSURANCE	ADDL INSD	SUBR WVD	POLICY NUMBER	POLICY EFF (MM/DD/YYYY)	POLICY EXP (MM/DD/YYYY)	LIMITS
A	<input checked="" type="checkbox"/> COMMERCIAL GENERAL LIABILITY <input type="checkbox"/> CLAIMS-MADE <input checked="" type="checkbox"/> OCCUR GEN'L AGGREGATE LIMIT APPLIES PER: <input checked="" type="checkbox"/> POLICY <input type="checkbox"/> PRO-JECT <input type="checkbox"/> LOC OTHER:	Y	Y	U21AC108338-03	10/3/2021	10/3/2022	EACH OCCURRENCE \$ 1,000,000 DAMAGE TO RENTED PREMISES (Ea occurrence) \$ 100,000 MED EXP (Any one person) \$ 5,000 PERSONAL & ADV INJURY \$ 1,000,000 GENERAL AGGREGATE \$ 2,000,000 PRODUCTS - COMP/OP AGG \$ 2,000,000
	AUTOMOBILE LIABILITY <input type="checkbox"/> ANY AUTO <input type="checkbox"/> OWNED AUTOS ONLY <input type="checkbox"/> SCHEDULED AUTOS <input type="checkbox"/> NON-OWNED AUTOS ONLY <input type="checkbox"/> HIRED AUTOS ONLY						COMBINED SINGLE LIMIT (Ea accident) \$ BODILY INJURY (Per person) \$ BODILY INJURY (Per accident) \$ PROPERTY DAMAGE (Per accident) \$
A	<input checked="" type="checkbox"/> UMBRELLA LIAB <input checked="" type="checkbox"/> OCCUR <input checked="" type="checkbox"/> EXCESS LIAB <input type="checkbox"/> CLAIMS-MADE DED RETENTION \$			U21AC108338-03	10/3/2021	10/3/2022	EACH OCCURRENCE \$ 1,000,000 AGGREGATE \$ 1,000,000
B	WORKERS COMPENSATION AND EMPLOYERS' LIABILITY ANY PROPRIETOR/PARTNER/EXECUTIVE OFFICER/MEMBER EXCLUDED? (Mandatory in NH) If yes, describe under DESCRIPTION OF OPERATIONS below	Y/N	N/A	Y	10650887-2021	10/29/2021	<input checked="" type="checkbox"/> PER STATUTE <input type="checkbox"/> OTH-ER E.L. EACH ACCIDENT \$ 500,000 E.L. DISEASE - EA EMPLOYEE \$ 500,000 E.L. DISEASE - POLICY LIMIT \$ 500,000

DESCRIPTION OF OPERATIONS / LOCATIONS / VEHICLES (ACORD 101, Additional Remarks Schedule, may be attached if more space is required)

COMMERCIAL PLUMBING, HEATING, & AIR CONDITIONING.
 Nassau County Board of County Commissioners is listed as an Additional Insured on the General Liability policy on a primary & noncontributory basis.
 A Waiver of Subrogation is provided in favor of Nassau County Board of County Commissioners for General Liability and Workers Compensation.

CERTIFICATE HOLDER	CANCELLATION
NASSAU COUNTY BOARD OF COUNTY COMMISSIONERS 96135 NASSAU PL YULEE, FL 32097	SHOULD ANY OF THE ABOVE DESCRIBED POLICIES BE CANCELLED BEFORE THE EXPIRATION DATE THEREOF, NOTICE WILL BE DELIVERED IN ACCORDANCE WITH THE POLICY PROVISIONS.
	AUTHORIZED REPRESENTATIVE



CERTIFICATE OF LIABILITY INSURANCE

DATE (MM/DD/YYYY)
07/05/2022

THIS CERTIFICATE IS ISSUED AS A MATTER OF INFORMATION ONLY AND CONFERS NO RIGHTS UPON THE CERTIFICATE HOLDER. THIS CERTIFICATE DOES NOT AFFIRMATIVELY OR NEGATIVELY AMEND, EXTEND OR ALTER THE COVERAGE AFFORDED BY THE POLICIES BELOW. THIS CERTIFICATE OF INSURANCE DOES NOT CONSTITUTE A CONTRACT BETWEEN THE ISSUING INSURER(S), AUTHORIZED REPRESENTATIVE OR PRODUCER, AND THE CERTIFICATE HOLDER.

IMPORTANT: If the certificate holder is an ADDITIONAL INSURED, the policy(ies) must be endorsed. SUBROGATION IS WAIVED, subject to the terms and conditions of the policy, certain policies may require an endorsement. A statement on this certificate does not confer rights to the certificate holder in lieu of such endorsement(s).

PRODUCER GARY ANDERSON, AGENT PO BOX 1967 CALLAHAN, FL 32011 	CONTACT NAME: Gary Anderson PHONE (A/C, No, Ext): 904-879-4866 E-MAIL ADDRESS: 	FAX (A/C, No): 904-879-5685
	INSURER(S) AFFORDING COVERAGE	
INSURED MCS MECHANICAL CONTRACTOR INC 3081 BARBARA LN HILLIARD FL 32046-5615	INSURER A: State Farm Mutual Automobile Insurance Company NAIC # 25178	
	INSURER B:	
	INSURER C:	
	INSURER D:	
	INSURER E:	

COVERAGES **CERTIFICATE NUMBER:** **REVISION NUMBER:**

THIS IS TO CERTIFY THAT THE POLICIES OF INSURANCE LISTED BELOW HAVE BEEN ISSUED TO THE INSURED NAMED ABOVE FOR THE POLICY PERIOD INDICATED. NOTWITHSTANDING ANY REQUIREMENT, TERM OR CONDITION OF ANY CONTRACT OR OTHER DOCUMENT WITH RESPECT TO WHICH THIS CERTIFICATE MAY BE ISSUED OR MAY PERTAIN, THE INSURANCE AFFORDED BY THE POLICIES DESCRIBED HEREIN IS SUBJECT TO ALL THE TERMS, EXCLUSIONS AND CONDITIONS OF SUCH POLICIES. LIMITS SHOWN MAY HAVE BEEN REDUCED BY PAID CLAIMS.

INSR LTR	TYPE OF INSURANCE	ADDL INSR	SUBR WVD	POLICY NUMBER	POLICY EFF (MM/DD/YYYY)	POLICY EXP (MM/DD/YYYY)	LIMITS
	GENERAL LIABILITY <input type="checkbox"/> COMMERCIAL GENERAL LIABILITY <input type="checkbox"/> CLAIMS-MADE <input type="checkbox"/> OCCUR GEN'L AGGREGATE LIMIT APPLIES PER: <input type="checkbox"/> POLICY <input type="checkbox"/> PRO-JECT <input type="checkbox"/> LOC						EACH OCCURRENCE \$ DAMAGE TO RENTED PREMISES (Ea occurrence) \$ MED EXP (Any one person) \$ PERSONAL & ADV INJURY \$ GENERAL AGGREGATE \$ PRODUCTS - COMPOP AGG \$ \$
A	AUTOMOBILE LIABILITY <input type="checkbox"/> ANY AUTO <input type="checkbox"/> ALL OWNED AUTOS <input type="checkbox"/> HIRED AUTOS <input checked="" type="checkbox"/> SCHEDULED AUTOS <input type="checkbox"/> NON-OWNED AUTOS	Y	Y	G81 1912-C23-59B	03/23/2022	09/23/2022	COMBINED SINGLE LIMIT (Ea accident) \$ BODILY INJURY (Per person) \$ 1,000,000 BODILY INJURY (Per accident) \$ 1,000,000 PROPERTY DAMAGE (Per accident) \$ 1,000,000 \$
	UMBRELLA LIAB <input type="checkbox"/> OCCUR EXCESS LIAB <input type="checkbox"/> CLAIMS-MADE DED <input type="checkbox"/> RETENTION \$						EACH OCCURRENCE \$ AGGREGATE \$ \$
	WORKERS COMPENSATION AND EMPLOYERS' LIABILITY ANY PROPRIETOR/PARTNER/EXECUTIVE OFFICE/MEMBER EXCLUDED? (Mandatory in NH) If yes, describe under DESCRIPTION OF OPERATIONS below	Y/N	N/A				WC STATU-TORY LIMITS <input type="checkbox"/> OTH-ER <input type="checkbox"/> E.L. EACH ACCIDENT \$ E.L. DISEASE - EA EMPLOYEE \$ E.L. DISEASE - POLICY LIMIT \$

DESCRIPTION OF OPERATIONS / LOCATIONS / VEHICLES (Attach ACORD 101, Additional Remarks Schedule, if more space is required)
 2009 CHEVROLET 2500 PICKUP (VIN:GCHC59629E144759)

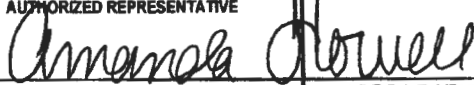
CERTIFICATE HOLDER NASSAU COUNTY BOARD OF COUNTY COMMISSIONERS 96135 NASSAU PL YULEE, FL 32097	CANCELLATION SHOULD ANY OF THE ABOVE DESCRIBED POLICIES BE CANCELLED BEFORE THE EXPIRATION DATE THEREOF, NOTICE WILL BE DELIVERED IN ACCORDANCE WITH THE POLICY PROVISIONS. AUTHORIZED REPRESENTATIVE 
--	--

Form **W-9**
(Rev. October 2018)
Department of the Treasury
Internal Revenue Service

Request for Taxpayer Identification Number and Certification

Give Form to the
requester. Do not
send to the IRS.

▶ Go to www.irs.gov/FormW9 for instructions and the latest information.

1 Name (as shown on your income tax return). Name is required on this line; do not leave this line blank.
MCS Mechanical Contractor Inc

2 Business name/disregarded entity name, if different from above

3 Check appropriate box for federal tax classification of the person whose name is entered on line 1. Check only **one** of the following seven boxes.

Individual/sole proprietor or single-member LLC

C Corporation

S Corporation

Partnership

Trust/estate

Limited liability company. Enter the tax classification (C=C corporation, S=S corporation, P=Partnership) ▶ _____

Note: Check the appropriate box in the line above for the tax classification of the single-member owner. Do not check LLC if the LLC is classified as a single-member LLC that is disregarded from the owner unless the owner of the LLC is another LLC that is not disregarded from the owner for U.S. federal tax purposes. Otherwise, a single-member LLC that is disregarded from the owner should check the appropriate box for the tax classification of its owner.

Other (see instructions) ▶ _____

4 Exemptions (codes apply only to certain entities, not individuals; see instructions on page 3):

Exempt payee code (if any) _____

Exemption from FATCA reporting code (if any) _____

(Applies to accounts maintained outside the U.S.)

5 Address (number, street, and apt. or suite no.) See instructions.
3081 Barbara Lane

6 City, state, and ZIP code
Hilliard, FL 32046

7 List account number(s) here (optional)

Requester's name and address (optional)

Part I Taxpayer Identification Number (TIN)

Enter your TIN in the appropriate box. The TIN provided must match the name given on line 1 to avoid backup withholding. For individuals, this is generally your social security number (SSN). However, for a resident alien, sole proprietor, or disregarded entity, see the instructions for Part I, later. For other entities, it is your employer identification number (EIN). If you do not have a number, see *How to get a TIN*, later.

Note: If the account is in more than one name, see the instructions for line 1. Also see *What Name and Number To Give the Requester* for guidelines on whose number to enter.

Social security number

			-			
--	--	--	---	--	--	--

or

Employer identification number

5	9	-	3	5	5	2	4	9	5
---	---	---	---	---	---	---	---	---	---

Part II Certification

Under penalties of perjury, I certify that:

- The number shown on this form is my correct taxpayer identification number (or I am waiting for a number to be issued to me); and
- I am not subject to backup withholding because: (a) I am exempt from backup withholding, or (b) I have not been notified by the Internal Revenue Service (IRS) that I am subject to backup withholding as a result of a failure to report all interest or dividends, or (c) the IRS has notified me that I am no longer subject to backup withholding; and
- I am a U.S. citizen or other U.S. person (defined below); and
- The FATCA code(s) entered on this form (if any) indicating that I am exempt from FATCA reporting is correct.

Certification instructions. You must cross out item 2 above if you have been notified by the IRS that you are currently subject to backup withholding because you have failed to report all interest and dividends on your tax return. For real estate transactions, item 2 does not apply. For mortgage interest paid, acquisition or abandonment of secured property, cancellation of debt, contributions to an individual retirement arrangement (IRA), and generally, payments other than interest and dividends, you are not required to sign the certification, but you must provide your correct TIN. See the instructions for Part II, later.

Sign Here Signature of U.S. person ▶ *[Signature]* Date ▶ **4/5/2022**

General Instructions

Section references are to the Internal Revenue Code unless otherwise noted.

Future developments. For the latest information about developments related to Form W-9 and its instructions, such as legislation enacted after they were published, go to www.irs.gov/FormW9.

Purpose of Form

An individual or entity (Form W-9 requester) who is required to file an information return with the IRS must obtain your correct taxpayer identification number (TIN) which may be your social security number (SSN), individual taxpayer identification number (ITIN), adoption taxpayer identification number (ATIN), or employer identification number (EIN), to report on an information return the amount paid to you, or other amount reportable on an information return. Examples of information returns include, but are not limited to, the following.

- Form 1099-INT (interest earned or paid)
- Form 1099-DIV (dividends, including those from stocks or mutual funds)
- Form 1099-MISC (various types of income, prizes, awards, or gross proceeds)
- Form 1099-B (stock or mutual fund sales and certain other transactions by brokers)
- Form 1099-S (proceeds from real estate transactions)
- Form 1099-K (merchant card and third party network transactions)
- Form 1098 (home mortgage interest), 1098-E (student loan interest), 1098-T (tuition)
- Form 1099-C (canceled debt)
- Form 1099-A (acquisition or abandonment of secured property)

Use Form W-9 only if you are a U.S. person (including a resident alien), to provide your correct TIN.

If you do not return Form W-9 to the requester with a TIN, you might be subject to backup withholding. See What is backup withholding, later.

Certificate Of Completion

Envelope Id: 872471F1992049559E23565961F40200 Status: Completed
 Subject: Please DocuSign: CM3207 - MCS Mechanical Contractor - Outside Air & Spray Foam Install - \$198733.00
 Source Envelope:
 Document Pages: 34 Signatures: 10 Envelope Originator:
 Certificate Pages: 6 Initials: 10 Evelyn Burton
 AutoNav: Enabled eburton@nassaucountyfl.com
 Envelopeld Stamping: Enabled IP Address: 50.238.237.26
 Time Zone: (UTC-05:00) Eastern Time (US & Canada)

Record Tracking

Status: Original 7/11/2022 10:10:52 AM	Holder: Evelyn Burton eburton@nassaucountyfl.com	Location: DocuSign
Status: Original 7/14/2022 12:52:47 PM	Holder: Marshall Eyerman MEyerman@nassaucountyfl.com	Location: DocuSign

Signer Events

Signer Events	Signature	Timestamp
Doug Podiak dpodiak@nassaucountyfl.com Facilities Director Nassau County BOCC Security Level: Email, Account Authentication (None)	 Signature Adoption: Pre-selected Style Using IP Address: 50.238.237.26	Sent: 7/11/2022 10:42:34 AM Viewed: 7/11/2022 10:50:46 AM Signed: 7/11/2022 10:55:53 AM

Electronic Record and Signature Disclosure:
Not Offered via DocuSign

Lanaee Gilmore lgilmore@nassaucountyfl.com Procurement Director Nassau County BOCC Security Level: Email, Account Authentication (None)	 Signature Adoption: Pre-selected Style Using IP Address: 50.238.237.26	Sent: 7/11/2022 10:55:56 AM Viewed: 7/11/2022 12:18:57 PM Signed: 7/11/2022 12:19:06 PM
---	--	---

Electronic Record and Signature Disclosure:
Not Offered via DocuSign

Tracy Poore tpoore@nassaucountyfl.com OMB Admin Nassau County BOCC Security Level: Email, Account Authentication (None)	 Signature Adoption: Pre-selected Style Using IP Address: 50.238.237.26	Sent: 7/11/2022 12:19:10 PM Viewed: 7/11/2022 1:22:28 PM Signed: 7/11/2022 1:28:04 PM
---	--	---

Electronic Record and Signature Disclosure:
Not Offered via DocuSign

Daniel Fanger dfanger@nassaucountyfl.com Asst. OMB Director Nassau County BOCC Security Level: Email, Account Authentication (None)	 Signature Adoption: Pre-selected Style Using IP Address: 50.238.237.26	Sent: 7/11/2022 1:28:08 PM Viewed: 7/12/2022 2:33:45 PM Signed: 7/12/2022 2:34:13 PM
---	--	--

Electronic Record and Signature Disclosure:
Accepted: 1/12/2022 8:21:25 AM
ID: a674f252-535e-4d30-a29b-ba05d6cf52ef

Signer Events	Signature	Timestamp
<p>chris lacambra clacambra@nassaucountyfl.com OMB Director Nassau County BOCC Security Level: Email, Account Authentication (None)</p> <p>Electronic Record and Signature Disclosure: Not Offered via DocuSign</p>	<p><i>chris lacambra</i></p> <p>Signature Adoption: Pre-selected Style Using IP Address: 50.238.237.26</p>	<p>Sent: 7/12/2022 2:34:17 PM Viewed: 7/12/2022 3:35:19 PM Signed: 7/12/2022 3:35:26 PM</p>
<p>Denise C. May dmay@nassaucountyfl.com Assistant County Attorney Nassau County BOCC Security Level: Email, Account Authentication (None)</p> <p>Electronic Record and Signature Disclosure: Not Offered via DocuSign</p>	<p><i>Denise C. May</i></p> <p>Signature Adoption: Pre-selected Style Using IP Address: 50.238.237.26</p>	<p>Sent: 7/12/2022 3:35:30 PM Viewed: 7/12/2022 3:36:23 PM Signed: 7/12/2022 3:36:59 PM</p>
<p>Taco E. Pope, AICP tpope@nassaucountyfl.com County Manager Nassau County BOCC Security Level: Email, Account Authentication (None)</p> <p>Electronic Record and Signature Disclosure: Not Offered via DocuSign</p>	<p><i>Taco E. Pope AICP</i></p> <p>Signature Adoption: Pre-selected Style Using IP Address: 50.238.237.26</p>	<p>Sent: 7/12/2022 3:37:03 PM Viewed: 7/12/2022 4:11:07 PM Signed: 7/12/2022 4:11:18 PM</p>
<p>Michael Shott mcsmechanical@windstream.net President Security Level: Email, Account Authentication (None)</p> <p>Electronic Record and Signature Disclosure: Accepted: 7/14/2022 12:52:02 PM ID: e7d4788c-aa11-47b3-87a2-0b106af57026</p>	<p><i>Michael Shott</i></p> <p>Signature Adoption: Pre-selected Style Using IP Address: 98.20.179.197</p>	<p>Sent: 7/12/2022 4:11:22 PM Viewed: 7/14/2022 12:52:02 PM Signed: 7/14/2022 12:52:24 PM</p>
In Person Signer Events	Signature	Timestamp
Editor Delivery Events	Status	Timestamp
Agent Delivery Events	Status	Timestamp
Intermediary Delivery Events	Status	Timestamp
Certified Delivery Events	Status	Timestamp
Carbon Copy Events	Status	Timestamp
<p>Evelyn Burton eburton@nassaucountyfl.com Procurement Nassau County BOCC Security Level: Email, Account Authentication (None)</p> <p>Electronic Record and Signature Disclosure: Not Offered via DocuSign</p>	<div style="border: 1px solid blue; padding: 5px; text-align: center; font-weight: bold; color: blue;">COPIED</div>	<p>Sent: 7/14/2022 12:52:47 PM Viewed: 7/14/2022 12:52:47 PM Signed: 7/14/2022 12:52:47 PM</p>

Carbon Copy Events	Status	Timestamp
Clerk Admin ClerkServices@nassaucountyfl.com Security Level: Email, Account Authentication (None) Electronic Record and Signature Disclosure: Not Offered via DocuSign	COPIED	Sent: 7/14/2022 12:52:32 PM Viewed: 7/15/2022 8:44:17 AM
RLS Distro RLSDistribution@nassaucountyfl.com Security Level: Email, Account Authentication (None) Electronic Record and Signature Disclosure: Not Offered via DocuSign	COPIED	Sent: 7/14/2022 12:52:34 PM
Procurement Staff procurementstaff@nassaucountyfl.com Security Level: Email, Account Authentication (None) Electronic Record and Signature Disclosure: Not Offered via DocuSign	COPIED	Sent: 7/14/2022 12:52:37 PM
Tammy Conley tconley@nassaucountyfl.com Nassau County BOCC Security Level: Email, Account Authentication (None) Electronic Record and Signature Disclosure: Not Offered via DocuSign	COPIED	Sent: 7/14/2022 12:52:39 PM

Witness Events	Signature	Timestamp
----------------	-----------	-----------

Notary Events	Signature	Timestamp
---------------	-----------	-----------

Envelope Summary Events	Status	Timestamps
Envelope Sent	Hashed/Encrypted	7/11/2022 10:42:34 AM
Certified Delivered	Security Checked	7/14/2022 12:52:02 PM
Signing Complete	Security Checked	7/14/2022 12:52:24 PM
Completed	Security Checked	7/14/2022 12:52:39 PM

Payment Events	Status	Timestamps
----------------	--------	------------

Electronic Record and Signature Disclosure
--

ELECTRONIC RECORD AND SIGNATURE DISCLOSURE

From time to time, County of Nassau (we, us or Company) may be required by law to provide to you certain written notices or disclosures. Described below are the terms and conditions for providing to you such notices and disclosures electronically through the DocuSign system. Please read the information below carefully and thoroughly, and if you can access this information electronically to your satisfaction and agree to this Electronic Record and Signature Disclosure (ERSD), please confirm your agreement by selecting the check-box next to 'I agree to use electronic records and signatures' before clicking 'CONTINUE' within the DocuSign system.

Getting paper copies

At any time, you may request from us a paper copy of any record provided or made available electronically to you by us. You will have the ability to download and print documents we send to you through the DocuSign system during and immediately after the signing session and, if you elect to create a DocuSign account, you may access the documents for a limited period of time (usually 30 days) after such documents are first sent to you. After such time, if you wish for us to send you paper copies of any such documents from our office to you, you will be charged a \$0.00 per-page fee. You may request delivery of such paper copies from us by following the procedure described below.

Withdrawing your consent

If you decide to receive notices and disclosures from us electronically, you may at any time change your mind and tell us that thereafter you want to receive required notices and disclosures only in paper format. How you must inform us of your decision to receive future notices and disclosure in paper format and withdraw your consent to receive notices and disclosures electronically is described below.

Consequences of changing your mind

If you elect to receive required notices and disclosures only in paper format, it will slow the speed at which we can complete certain steps in transactions with you and delivering services to you because we will need first to send the required notices or disclosures to you in paper format, and then wait until we receive back from you your acknowledgment of your receipt of such paper notices or disclosures. Further, you will no longer be able to use the DocuSign system to receive required notices and consents electronically from us or to sign electronically documents from us.

All notices and disclosures will be sent to you electronically

Unless you tell us otherwise in accordance with the procedures described herein, we will provide electronically to you through the DocuSign system all required notices, disclosures, authorizations, acknowledgements, and other documents that are required to be provided or made available to you during the course of our relationship with you. To reduce the chance of you inadvertently not receiving any notice or disclosure, we prefer to provide all of the required notices and disclosures to you by the same method and to the same address that you have given us. Thus, you can receive all the disclosures and notices electronically or in paper format through the paper mail delivery system. If you do not agree with this process, please let us know as described below. Please also see the paragraph immediately above that describes the consequences of your electing not to receive delivery of the notices and disclosures electronically from us.

How to contact County of Nassau:

You may contact us to let us know of your changes as to how we may contact you electronically, to request paper copies of certain information from us, and to withdraw your prior consent to receive notices and disclosures electronically as follows:

To contact us by email send messages to: bsimmons@nassaucountyfl.com

To advise County of Nassau of your new email address

To let us know of a change in your email address where we should send notices and disclosures electronically to you, you must send an email message to us at bsimmons@nassaucountyfl.com and in the body of such request you must state: your previous email address, your new email address. We do not require any other information from you to change your email address.

If you created a DocuSign account, you may update it with your new email address through your account preferences.

To request paper copies from County of Nassau

To request delivery from us of paper copies of the notices and disclosures previously provided by us to you electronically, you must send us an email to bsimmons@nassaucountyfl.com and in the body of such request you must state your email address, full name, mailing address, and telephone number. We will bill you for any fees at that time, if any.

To withdraw your consent with County of Nassau

To inform us that you no longer wish to receive future notices and disclosures in electronic format you may:

- i. decline to sign a document from within your signing session, and on the subsequent page, select the check-box indicating you wish to withdraw your consent, or you may;
- ii. send us an email to bsimmons@nassaucountyfl.com and in the body of such request you must state your email, full name, mailing address, and telephone number. We do not need any other information from you to withdraw consent.. The consequences of your withdrawing consent for online documents will be that transactions may take a longer time to process..

Required hardware and software

The minimum system requirements for using the DocuSign system may change over time. The current system requirements are found here: <https://support.docusign.com/guides/signer-guide-signing-system-requirements>.

Acknowledging your access and consent to receive and sign documents electronically

To confirm to us that you can access this information electronically, which will be similar to other electronic notices and disclosures that we will provide to you, please confirm that you have read this ERSD, and (i) that you are able to print on paper or electronically save this ERSD for your future reference and access; or (ii) that you are able to email this ERSD to an email address where you will be able to print on paper or save it for your future reference and access. Further, if you consent to receiving notices and disclosures exclusively in electronic format as described herein, then select the check-box next to 'I agree to use electronic records and signatures' before clicking 'CONTINUE' within the DocuSign system.

By selecting the check-box next to 'I agree to use electronic records and signatures', you confirm that:

- You can access and read this Electronic Record and Signature Disclosure; and
- You can print on paper this Electronic Record and Signature Disclosure, or save or send this Electronic Record and Disclosure to a location where you can print it, for future reference and access; and
- Until or unless you notify County of Nassau as described above, you consent to receive exclusively through electronic means all notices, disclosures, authorizations, acknowledgements, and other documents that are required to be provided or made available to you by County of Nassau during the course of your relationship with County of Nassau.

BID TABULATION

NC22-007-ITB NCSO Mechanics Garage Outside Air System/Foam Insulation

Bid opening date: (Original due date 3/24/2022)

4/6/2022 (Addendum# 1-bid due date extended)

	Bidder #1	Bidder #2	Bidder #3	Bidder #4	Bidder #5
	MCS				
REQUIRED DOCUMENTS	Mechanical Contractor	Brooks Building Solutions	N/A	N/A	N/A
Response Price Sheet:					
Lump Sum Price per Scope	\$ 198,733.00	\$ 209,996.00			
FORMS - (Y/N)					
Signed ITB Cover Sheet	Y	N			
Addenda Acknowledgement	Y	N			
Bid Bond <i>(if over \$100k)</i>	Y	Y			
Public Entity Crimes Statement	Y	N			
Experience of Bidder	Y	N			
Drug-free Workplace Cert	Y	N			
E-Verify /Proof of Registration/MOU	Y	Y			
Certificate of Insurance	Y	Y			
W-9	Y	Y			
Licenses	Y	Y			

N

Note: